



User Guide

© Copyright 2018 HP Development Company, L.P.

HDMI, the HDMI Logo and High-Definition Multimedia Interface are trademarks or registered trademarks of HDMI Licensing LLC. Windows is either a registered trademark or trademark of Microsoft Corporation in the United States and/or other countries.

The information contained herein is subject to change without notice. The only warranties for HP products and services are set forth in the express warranty statements accompanying such products and services. Nothing herein should be construed as constituting an additional warranty. HP shall not be liable for technical or editorial errors or omissions contained herein.

Product notice

This guide describes features that are common to most models. Some features may not be available on your product. To access the latest user guide, go to <http://www.hp.com/support>, and follow the instructions to find your product. Then select **User Guides**.





Second Edition: January 2018

First Edition: January 2018

Document Part Number: L11434-002

About This Guide

This guide provides information on monitor features, setting up the monitor, using the software and technical specifications.

-
-  **WARNING!** Indicates a hazardous situation that, if not avoided, **could** result in death or serious injury.
 -  **CAUTION:** Indicates a hazardous situation that, if not avoided, **could** result in minor or moderate injury.
 -  **IMPORTANT:** Indicates information considered important but not hazard-related (for example, messages related to property damage). A notice alerts the user that failure to follow a procedure exactly as described could result in loss of data or in damage to hardware or software. Also contains essential information to explain a concept or to complete a task.
 -  **NOTE:** Contains additional information to emphasize or supplement important points of the main text.
 -  **TIP:** Provides helpful hints for completing a task.
-



This product incorporates HDMI technology.

Table of contents

1 Getting started	1
Important safety information	1
Product features and components	2
Features	2
Rear components	3
Front components	4
Setting up the monitor	5
Connecting the cables	5
Turning on the monitor	8
HP watermark and image retention policy	8
Mounting on a wall	9
VESA grid	10
2 Remote control	11
Installing the battery in the remote control	11
Handling the remote	11
Operating range of the remote control	12
General functions	13
3 Using the monitor	14
Downloading the monitor drivers	14
Using the on-screen display (OSD) menu	14
Assigning the function buttons	15
Using Auto-Sleep Mode	15
PIP / PBP	15
Mode	16
Position	16
Size	17
4 Support and troubleshooting	18
Solving common problems	18
Button lockouts	18
Using the auto-adjustment feature (analog input only)	19
Optimizing image performance (analog input only)	20
Contacting support	21
Preparing to call technical support	21

Locating the serial number and product number	22
5 Maintaining the monitor	23
Maintenance guidelines	23
Cleaning the monitor	24
Shipping the monitor	24
Appendix A Technical specifications	25
Preset display resolutions	26
Entering user modes	26
Energy saver feature	26
Appendix B Accessibility	28
Accessibility	28
Finding the technology tools you need	28
Our commitment	28
International Association of Accessibility Professionals (IAAP)	28
Finding the best assistive technology	29
Assessing your needs	29
Accessibility for HP products	29
Standards and legislation	30
Standards	30
Mandate 376 – EN 301 549	30
Web Content Accessibility Guidelines (WCAG)	30
Legislation and regulations	30
United States	31
21st Century Communications and Video Accessibility Act (CVAA)	31
Canada	31
Europe	32
United Kingdom	32
Australia	32
Worldwide	32
Useful accessibility resources and links	33
Organizations	33
Educational institutions	33
Other disability resources	33
HP links	33
Contacting support	34

1 Getting started

Important safety information

An AC power cord is included with the monitor. If another cord is used, use only a power source and connection appropriate for this monitor. For information on the correct AC power cord set to use with the monitor, see the *Product Notices* provided in your documentation kit.

 **WARNING!** To reduce the risk of electric shock or damage to the equipment:

- Plug the power cord into an AC outlet that is easily accessible at all times.
- Disconnect power from the computer by unplugging the power cord from the AC outlet.
- If provided with a 3-pin attachment plug on the power cord, plug the cord into a grounded (earthed) 3-pin outlet. Do not disable the power cord grounding pin, for example, by attaching a 2-pin adapter. The grounding pin is an important safety feature.

For your safety, do not place anything on power cords or cables. Arrange them so that no one may accidentally step on or trip over them. Do not pull on a cord or cable. When unplugging from the AC outlet, grasp the cord by the plug.

To reduce the risk of serious injury, read the *Safety & Comfort Guide* (provided with your user guides). It describes proper workstation setup and proper posture, health, and work habits for computer users. The *Safety & Comfort Guide* also provides important electrical and mechanical safety information. The *Safety & Comfort Guide* is also available on the Web at <http://www.hp.com/ergo>.

 **IMPORTANT:** For the protection of the monitor, as well as the computer, connect all power cords for the computer and its peripheral devices (such as a monitor, printer, scanner) to some form of surge protection device such as a power strip or uninterruptible power supply (UPS). Not all power strips provide surge protection; the power strips must be specifically labeled as having this capability. Use a power strip whose manufacturer offers a damage replacement policy so you can replace the equipment if surge protection fails.

Use the appropriate and correctly sized furniture designed to properly support your HP LCD monitor.

 **WARNING!** LCD monitors that are inappropriately situated on dressers, bookcases, shelves, desks, speakers, chests, or carts may fall over and cause personal injury.

Care should be taken to route all cords and cables connected to the LCD monitor so that they cannot be pulled, grabbed, or tripped over.

Be sure that the total ampere rating of the products connected to the AC outlet does not exceed the current rating of the outlet, and that the total ampere rating of the products connected to the cord does not exceed the rating of the outlet, and that the total ampere rating of the products connected to the cord does not exceed the rating of the cord. Look on the power label to determine the ampere rating (AMPS or A) for each device.

Install the monitor near an AC outlet that you can easily reach. Disconnect the monitor by grasping the plug firmly and pulling it from the AC outlet. Never disconnect the monitor by pulling the cord.

Do not drop the monitor or place it on an unstable surface.

 **NOTE:** This product is suitable for entertainment purposes. Consider placing the monitor in a controlled luminous environment to avoid interference from surrounding light and bright surfaces that may cause disturbing reflections from the screen.

Product features and components

Features

The monitors include the following features:

- 139.7 cm (55-inch) diagonal viewable screen area with 3840 × 2160 resolution, plus full-screen support for lower resolutions; includes custom scaling for maximum image size while preserving original aspect ratio
- Anti-glare panel with an LED backlight
- Wide viewing angle to allow viewing from a sitting or standing position, or moving from side to side
- VGA and DisplayPort video inputs
- HDMI (High-Definition Multimedia Interface) video input × 3
- PIP (picture-in-picture) functionality to enable the VGA, DisplayPort and HDMI inputs to be viewed in a small secondary window or side-by-side on the main window
- Audio input jack
- Headphone jack
- USB (only for service)
- Plug and Play capability if supported by your operating system
- Support VESA compliant mounting interface: 400 × 200 mm (15.75 × 7.87 in) hole pattern
- On-screen display (OSD) adjustments in several languages for easy setup and screen optimization
- High-Bandwidth Digital Content Protection (HDCP) copy protection on all digital inputs
- Energy saver feature to meet requirements for reduced power consumption



NOTE: For safety and regulatory information, see the *Product Notices* provided in your documentation kit. To access the latest user guide, go to <http://www.hp.com/support>, and follow the instructions to find your product. Then select **User Guides**.

Rear components

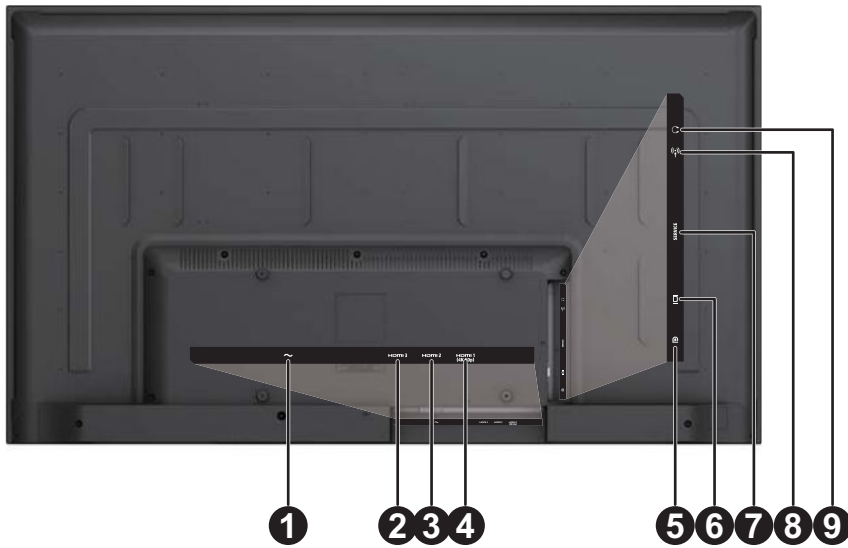

Component	Function
1 Power connector	Connects the power cord to the monitor.
2 HDMI3 port (HDMI 1.4)	Connects an HDMI cable to the monitor.
3 HDMI2 port (HDMI 1.4)	Connects an HDMI cable to the monitor.
4 HDMI1 port (HDMI 2.0)	Connects an HDMI cable to the monitor.
5 DisplayPort (DisplayPort 1.2)	Connects a DisplayPort cable to the monitor.
6 VGA port	Connects a VGA cable to the monitor.
7 USB port	Connects optional USB devices to the monitor (only for service).
8 Audio-in jack	Connects an audio cable to the monitor.
9 Audio-out (headphone) jack	Connects headphones to the monitor.

Front components

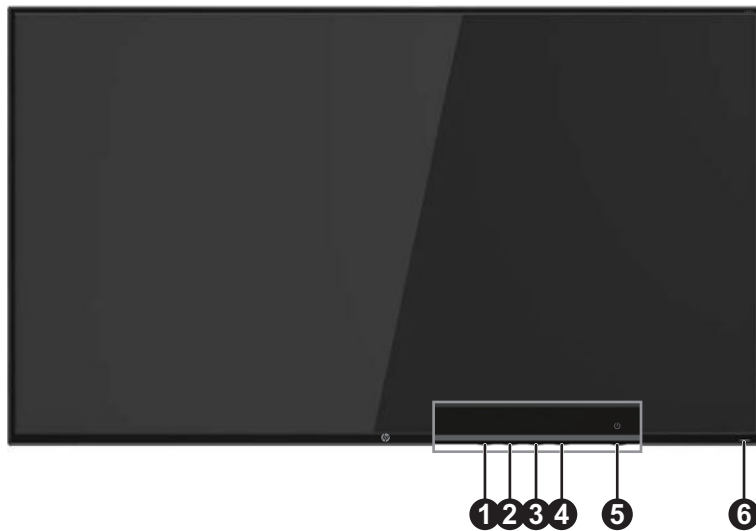

Component	Function
1 Menu button	Opens the OSD menu or selects items on the OSD menu.
2 Information / Auto Adjustment / Minus button	Information or Auto Adjustment: If the OSD menu is inactive, press to show the monitor information.. Auto Adjustment: If the OSD menu is inactive and the monitor is connected to a VGA source, press to perform auto adjustment. Minus: If the OSD menu is on, press to navigate backward through the OSD menu and decrease adjustment levels.
3 Viewing Modes / Plus button	Viewing Modes: If the OSD menu is inactive, press to activate the Viewing Modes to choose different video settings. Plus: If the OSD menu is on, press to navigate forward through the OSD menu and increase adjustment levels.
4 Next Input / Exit button	Next Input: If the OSD menu is inactive, press to switch the video signal input. Exit: If the OSD menu is on, press to save any changes made, and exit the OSD menu.
5 Power button	Turns the monitor on or standby.
6 LED indicator light / IR receiver	LED indicator: Blue indicates power on. Amber indicates power saving mode. IR receiver: Receives signals from the remote control.



NOTE: Buttons 2 through 4 can be assigned a different function by the user.

To view an OSD menu simulator, visit the HP Customer Self Repair Services Media Library at <http://www.hp.com/go/sml>.

Setting up the monitor

Connecting the cables

 **NOTE:** The monitor ships with select cables. Not all cables shown in this section are included with the monitor.

1. Place the monitor in a convenient, well-ventilated location near the computer.
2. Connect a video cable.

 **NOTE:** The monitor will automatically determine which inputs have valid video signals. The inputs can be selected by pressing the **Menu** button to access the On-Screen Display (OSD) menu and selecting **Input Control**.

- Connect one end of a VGA cable to the VGA connector on the rear of the monitor and the other end to the VGA connector on the source device.

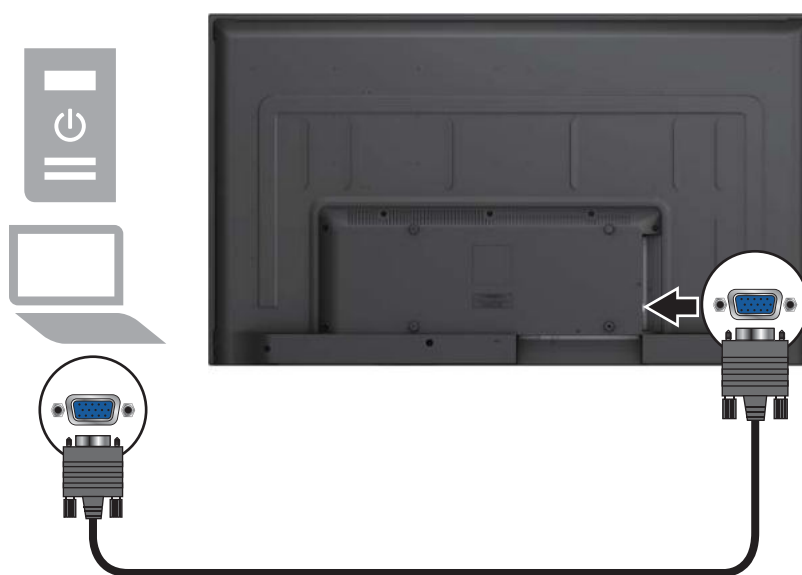

- Connect one end of an HDMI cable to the HDMI1, HDMI2, or HDMI3 connector on the rear of the monitor and the other end to a HDMI connector on the source device.

 **NOTE:** Use a high-speed HDMI cable. High-speed HDMI cables can handle definition beyond 1080p. Check the computer environment if you cannot hear audio in HDMI mode. Some computers require you to manually change the default audio output to HDMI.

If you want to use HDMI-PC mode, you must set the input label to PC mode.

When HDMI PC is used, a compatibility problem might occur.

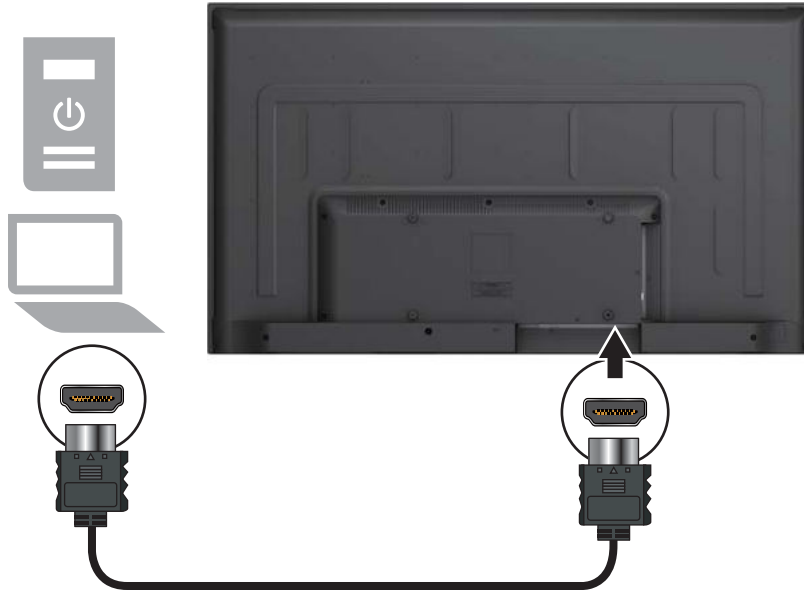

- Connect one end of an DisplayPort cable to the DisplayPort connector on the rear of the monitor and the other end to a DisplayPort connector on the source device.

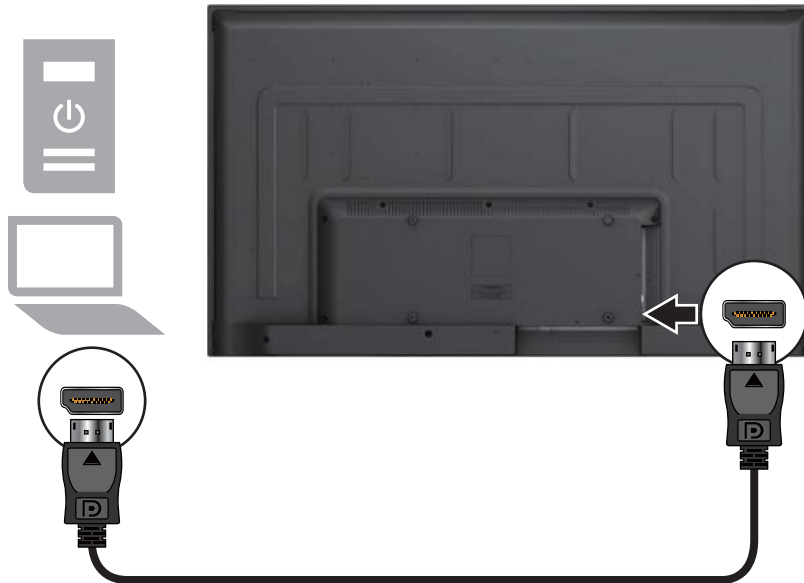

3. Connect one end of the power cord to the monitor and the other end to a grounded AC outlet.

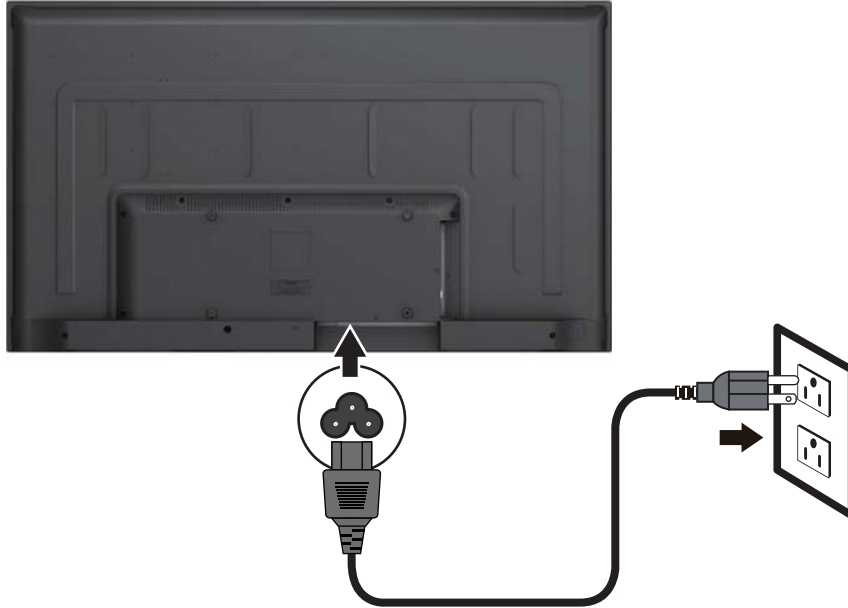

⚠ WARNING! To reduce the risk of electric shock or damage to the equipment:

Do not disable the power cord grounding plug. The grounding plug is an important safety feature.

Plug the power cord into a grounded (earthed) AC outlet that is easily accessible at all times.

Disconnect power from the equipment by unplugging the power cord from the AC outlet.

For your safety, do not place anything on power cords or cables. Arrange them so that no one may accidentally step on or trip over them. Do not pull on a cord or cable. When unplugging the power cord from the AC outlet, grasp the cord by the plug.

Turning on the monitor

1. Press the power button on the source device to turn it on.
2. Press the power button on the bottom of the monitor to turn it on.



IMPORTANT: Burn-in damage may occur on monitors that display the same static image on screen for 12 or more consecutive hours of nonuse. To avoid burn-in damage, always activate a screen saver application or turn off the monitor when it will not be in use for a prolonged period. Image retention is a condition that may occur on all LCD screens. A burned-in image on the monitor is not covered under the HP warranty.

NOTE: If pressing the power button has no effect, the Power Button Lockout feature may be enabled. To disable this feature, press and hold the monitor power button for 10 seconds.

You can disable the power LED in the OSD menu. Press the **Menu** button on the bottom of the monitor, and then select **Power Control**, select **Power LED**, and then select **Off**.

When the monitor is turned on, a **Monitor Status** message displays for five seconds. The message shows which input is the current active signal, the status of the auto-switch source setting (On or Off; factory default is On), the current preset display resolution, and the recommended preset display resolution.

The monitor automatically scans the signal inputs for an active input and uses that input for the monitor.

HP watermark and image retention policy

The ADS monitor models are designed with ADS (Advanced Super Dimension Switch) display technology which provides ultra-wide viewing angles and advanced image quality. ADS monitors are suitable for a wide variety of advanced image quality applications. This panel technology, however, is not suitable for applications that exhibit static, stationary or fixed images for long periods of time without the use of screen savers. These types of applications may include camera surveillance, video games, marketing logos, and templates that are displayed on the screen for a prolonged period of time. Static images may cause image retention damage that could look like stains or watermarks on the monitor's screen.

Monitors in use for 24 hours per day that result in image retention damage are not covered under the HP warranty. To avoid image retention damage, always turn off the monitor when it is not in use or use the power management setting, if supported on your system, to turn off the display when the system is idle.

Mounting on a wall

For proper ventilation, allow a clearance of 10 cm on each side and from the wall. Detailed installation instructions are available from the manufacturer of the mounting equipment.

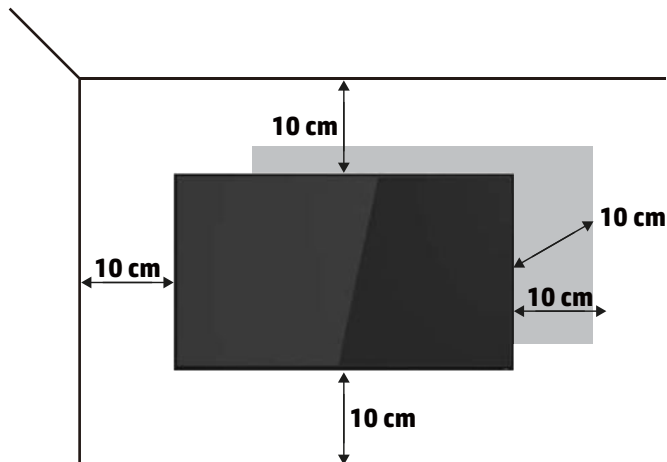

If you intend to mount the display to a wall, attach a wall mounting interface (optional parts) to the back of the set.

When you install the display using a wall mounting interface (optional parts), attach it carefully so it will not fall.

⚠ CAUTION: Disconnect the power cord first, and then move or install the display. Otherwise electric shock may occur.

If you install the display on a ceiling or slanted wall, it may fall and result in severe injury.

Use an authorized HP wall mount and contact the local dealer or qualified personnel.

Do not over tighten the screws as this may cause damage to the display and void your warranty.

Use the screws and wall mounts that meet the VESA standard. Any damages or injuries by misuse or using an improper accessory are not covered by the warranty.

1. Use a wall mount and screws in accordance with VESA standards.

If you use screws longer than the VESA standard, the display might be damaged internally.

If you use improper screws, the product might be damaged and drop from mounted position. In this case, HP is not responsible for damage.

2. Use VESA standard as follows:

- 785 mm (31 inch) or greater
- Fastening screw: 6.0 mm (diameter) × 1.0 mm (pitch) × 10 mm (length)

3. Unit without base weight = 16 kg. The equipment and its associated mounting means still remain secure during the test. For use only with UL Listed Wall Mount Bracket with minimum weight/load: 16 kg.

📝 NOTE: The wall mount bracket is optional. You can obtain additional accessories from your local dealer.

The length of screws may differ depending on the wall mount. Be sure to use the proper length. For more information, refer to the manufacturer's instructions supplied with the wall mount.

VESA grid

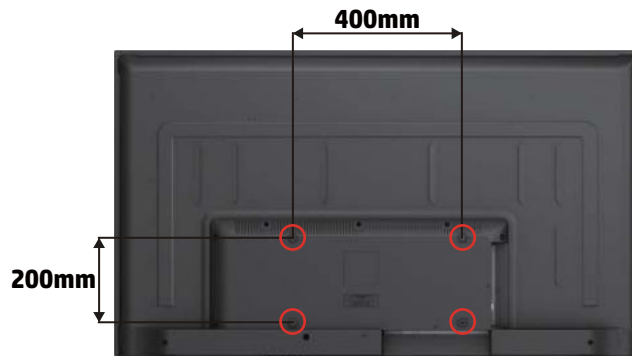

Model name	VESA grid
LD5512	400 (H) × 200 (V) mm

⚠ CAUTION: To prevent the display from falling:

- For wall or ceiling installation, we recommend installing the display with metal brackets which are commercially available. For detailed installation instructions, refer to the guide received with the respective bracket.
- To lessen the probability of injury and damage resulting from fall of the display in case of earthquake or other natural disaster, be sure to consult the bracket manufacturer for installation location.

2 Remote control

Installing the battery in the remote control

The remote control ships with battery.

To replace battery, open the battery cover, replace battery (3V CR2025) matching (+) and (-) ends to the inside the compartment, and close the battery cover. To remove the battery, perform the installation actions in reverse.



⚠ CAUTION: The incorrect use of battery can result in leaks or bursting. Be sure to follow these instructions:

- Place “CR2025” battery matching the (+) and (-) signs on each battery to the (+) and (-) signs of the battery compartment.
- Do not mix battery types.
- Do not combine new battery with used ones. It causes shorter life or leakage of battery.
- Remove the dead battery immediately to prevent them from liquid leaking in the battery compartment. Don't touch exposed battery acid, as it can damage your skin.

📝 NOTE: If you do not intend to use the remote control for a long period, remove the battery.

Handling the remote

- Do not subject to strong shock.
- Do not allow water or other liquid to splash the remote control. If the remote control gets wet, wipe it dry immediately.
- Avoid exposure to heat and steam.
- Other than to install the battery, do not open the remote control.

Operating range of the remote control

Point the front of the remote control toward this display's remote control sensor when pressing a button.

Use the remote control within a distance of less than 5 m (16 ft) from this display's sensor, and a horizontal and vertical angle of less than 30 degrees.

 **NOTE:** The remote control may not function properly when the remote control sensor on this display is under direct sunlight or strong illumination, or when there is an obstacle in the path of signal transmission.

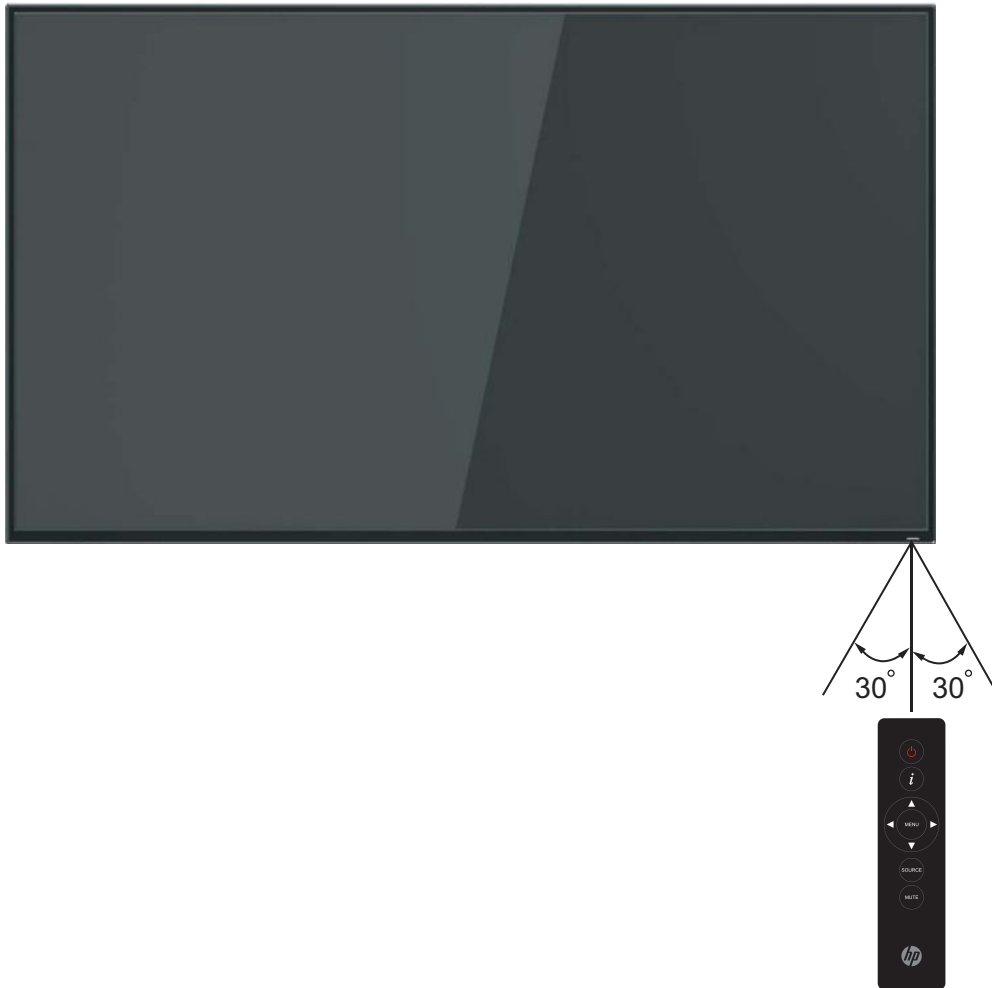

General functions

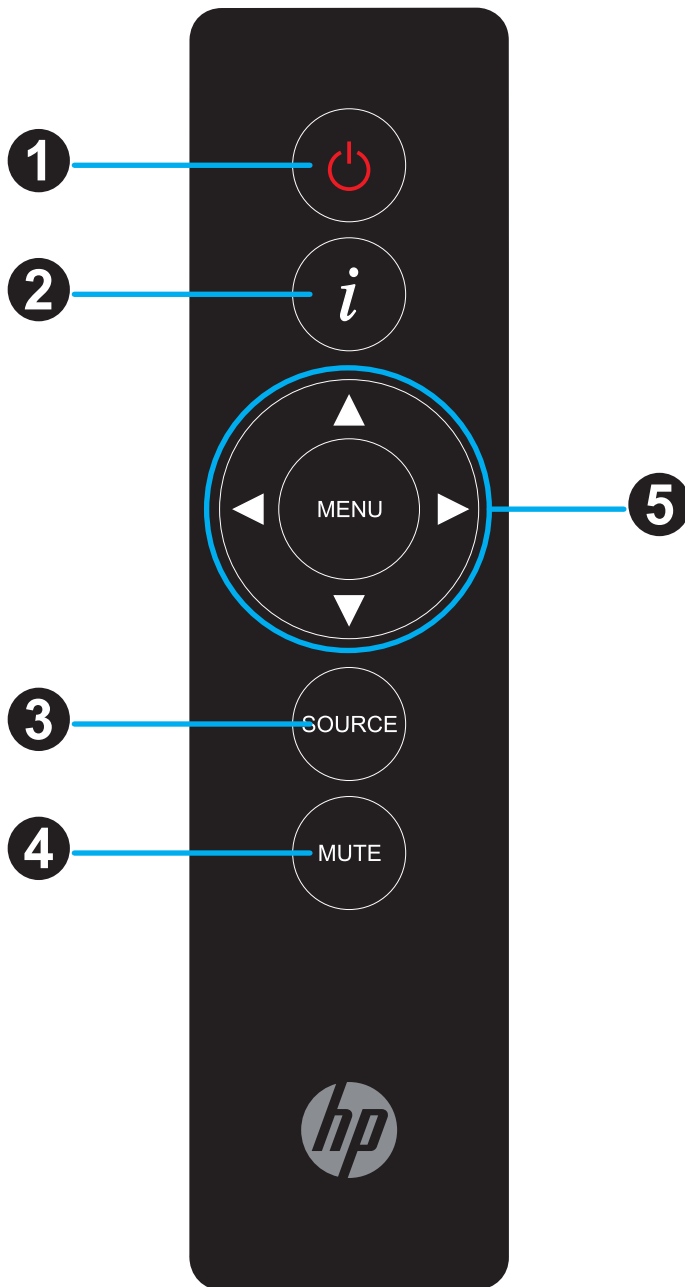

Control	Function
1 Power button	Turns the monitor on or off.
2 Information button	Displays information about current activity.
3 SOURCE button	Selects the input source. Press button to select from DisplayPort, HDMI 1, HDMI 2, HDMI 3, or VGA.
4 MUTE button	Press to turn the mute function on/off.
5 Navigation and MENU buttons	Navigation: Scrolls through menus or options. MENU: Accesses the main menus or saves your input and exits menus.

3 Using the monitor

Downloading the monitor drivers

You can download the latest version of .INF and .ICM files from the HP monitors support web site.

To download the files:

1. Go to <http://www.hp.com/support>.
2. Select **Get software and drivers**.
3. Follow the on-screen instructions to download the software.

Using the on-screen display (OSD) menu

Use the OSD menu to adjust the screen image based on your preferences. You can access and make adjustments in the OSD menu using the buttons on the bottom side of the front bezel of the monitor.

To access the OSD menu and make adjustments, do the following:

1. If the monitor is not already on, press the power button to turn on the monitor.
2. To access the OSD menu, press one of the function buttons on the bottom side of the front bezel of the monitor to activate the buttons, and then press the **Menu** button to open the OSD.
3. Use the three function buttons to navigate, select, and adjust the menu choices. The button labels are variable depending on the menu or submenu that is active.

The following table lists the menu selections in the OSD menu.

Menu item	Description
Brightness	Adjusts the brightness level of the screen.
Contrast	Adjusts the screen contrast.
Color Control	Selects and adjusts the screen color.
Input Control	Selects the video input signal.
Image Control	Adjusts the screen image.
PIP Control	Selects and adjusts the Picture-in-Picture (PIP) image.
Power Control	Adjusts the power settings.
Menu Control	Adjusts the OSD menu and assigns new function button controls.
Management	Enables/disables DDC/CI support and returns all OSD menu settings to the default settings.
Language	Selects the language in which the OSD menu is displayed. The default is English.
Information	Displays important information about the monitor.
Exit	Exits the OSD menu screen.

Assigning the function buttons

You can change the function buttons from their default values so that when the buttons are activated, you can quickly access commonly used menu items.

To assign a new function to a function button:

1. Press one of the three function buttons to activate the buttons, and then press the **Menu** button to open the OSD.
2. In the OSD menu, select **Menu Control**, select **Assign Buttons**, and then select one of the available options for the button you want to assign.



NOTE: You can reassign only the three function buttons. You can not reassign the Menu button or the Power button.

Using Auto-Sleep Mode

The monitor supports an OSD menu option called Auto-Sleep Mode that allows you to enable or disable a reduced power state for the monitor. When Auto-Sleep Mode is enabled (enabled by default), the monitor will enter a reduced power state when the computer signals low power mode (absence of either horizontal or vertical sync signal).

Upon entering this reduced power state (sleep mode), the monitor screen is blanked, the backlight is turned off, and the power light turns amber. The monitor draws less than 0.5 W of power when in this reduced power state. The monitor will wake from the sleep mode when the computer sends an active signal to the monitor (for example, if you activate the mouse or keyboard).

You can disable the Auto-Sleep Mode in the OSD menu. Press a function button, and then press the **Menu** button to open the OSD menu. In the OSD menu, press **Power Control**, select **Auto-Sleep Mode**, and then select **Off**.

PIP / PBP

This function allows you to watch two screens from different sources at the same time.

In PIP mode, you can change the size and position of the subscreen.

In PBP mode, the aspect ration is fixed at 16:9 and the Aspect Ratio option in the PICTURE menu is disabled.

The values selected in the main menu determine the picture quality of the subscreen.

When the power is turned off or on, the PIP and PBP modes are disabled.

Mode

Mode	Description
Picture in Picture (PIP)	Displays the subscreen in the main screen.
Picture by Picture (PBP)	Displays the sub screen next to the main screen.

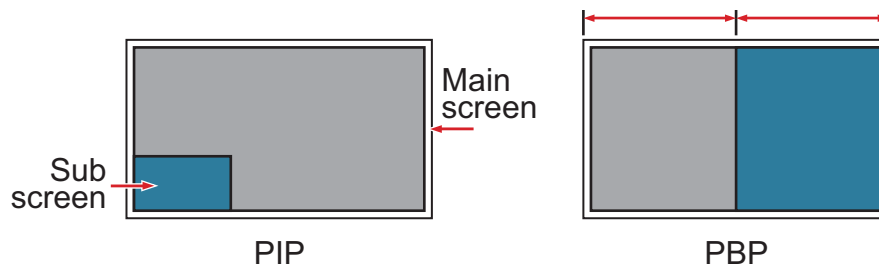

Position

In PIP mode, you can position the subscreen in the top left, bottom left, top right, or bottom right of the main screen.

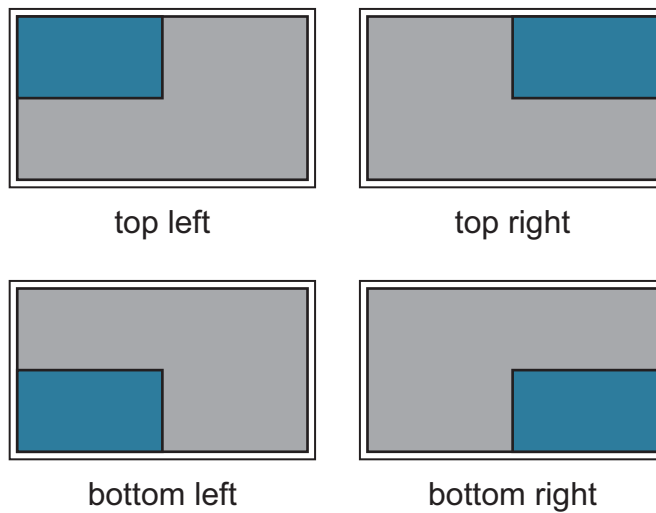

Size

In PIP mode, you can adjust the size of the subscreen in the main screen.

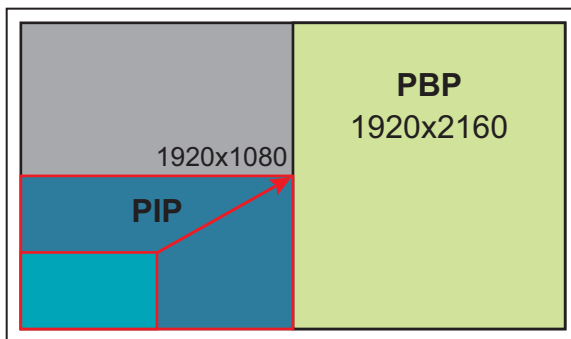

< 3840x2160 >

4 Support and troubleshooting

Solving common problems

The following table lists possible problems, the possible cause of each problem, and the recommended solutions.

Problem	Possible Cause	Solution
Screen is blank or video is flashing.	Power cord is disconnected.	Connect the power cord.
	Power button is turned off.	Press the power button. NOTE: If pressing the power button has no effect, press and hold the power button for 10 seconds to disable the Power Button Lockout feature.
	Video cable is improperly connected.	Connect the video cable properly. For more information, see Connecting the cables on page 5 .
	System is in sleep mode.	Press any key on the keyboard or move the mouse to inactivate the screen blanking utility.
	Video card is incompatible.	Open the OSD menu and select the Input Control menu. Set Auto-Switch Input to Off and manually select the input.
Image appears blurred, indistinct, or too dark.	Brightness setting is too low.	Open the OSD menu and select Brightness to adjust the brightness scale as needed.
Check Video Cable is displayed on screen.	Monitor video cable is disconnected.	Connect the appropriate video signal cable between the computer and monitor. Be sure that the computer power is off while connecting the video cable.
Input Signal Out of Range is displayed on screen.	Video resolution and/or refresh rate are set higher than the monitor supports.	Change the settings to a supported setting. See Preset display resolutions on page 26 .
The monitor is off but it did not seem to enter a low-power mode.	The monitor's power saving control is disabled.	Open the OSD menu and select Power Control , select Auto-Sleep Mode , and then set auto-sleep to On .
OSD Lockout is displayed.	The monitor's OSD Lockout function is enabled.	Press and hold the Menu button for 10 seconds to disable the OSD Lockout function.
Power Button Lockout is displayed.	The monitor's Power Button Lockout function is enabled.	Press and hold the power button for 10 seconds to unlock the Power Button Lockout function.

Button lockouts

Holding down the power button or **Menu** button for ten seconds will lock out the functionality of that button. You can restore the functionality by holding the button down again for ten seconds. This functionality is only available when the monitor is powered on, displaying an active signal, and the OSD menu is closed.

Using the auto-adjustment feature (analog input only)

When you set up the monitor for the first time, conduct a factory reset of the computer, or change the resolution of the monitor, the auto-adjustment function automatically engages, and attempts to optimize your screen for you.

 **NOTE:** If the monitor is using an input other than VGA, do not use this procedure.

If the monitor is using a VGA (analog) input, this procedure can correct the following image quality conditions:

- Fuzzy or unclear focus
- Ghosting, streaking, or shadowing effects
- Faint vertical bars
- Thin, horizontal scrolling lines
- An off-center feature

To use the auto-adjustment feature:

1. Before adjusting, wait at least 20 minutes after turning on the monitor.
2. Press the **Menu** button. From the OSD menu, select **Image Control**, and then select **Auto-Adjustment**.
3. Display the auto-adjustment test pattern on your screen.

 **NOTE:** You can download the auto-adjustment test pattern utility from <http://www.hp.com/support>.

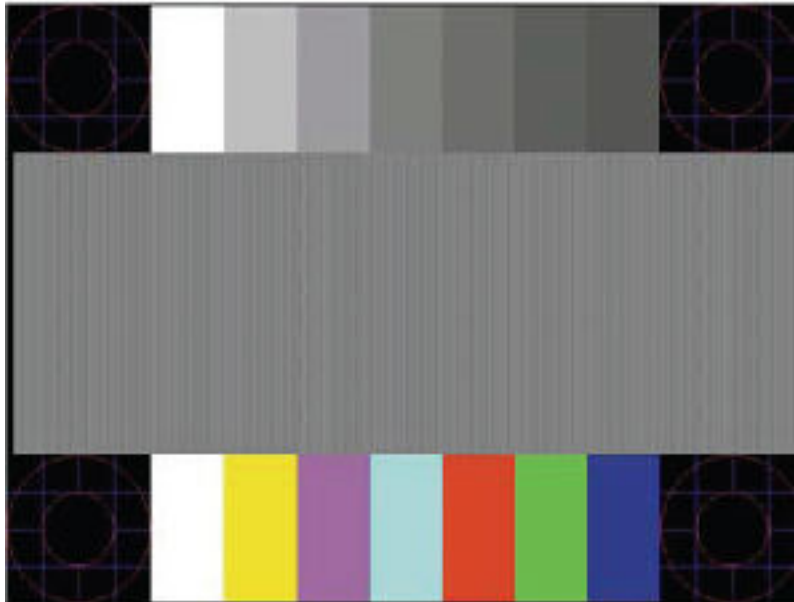

4. Press the **Esc** key or any other key on the keyboard to exit the test pattern.

For VGA input, you can also optimize the screen performance by pressing the auto-adjustment button on the monitor and using the auto-adjustment test pattern utility available on <http://www.hp.com/support>.

Optimizing image performance (analog input only)

Two controls available in the OSD menu can be adjusted to improve image performance: Clock and Phase. Use these controls only when the auto-adjustment function does not provide a satisfactory image.

- **Clock:** Increase or decrease the value to minimize any vertical bars or stripes visible on the screen background.
- **Phase:** Increase or decrease the value to minimize video flickering or blurring.

When adjusting the Clock and Phase values, if the monitor images become distorted, continue adjusting the values until the distortion disappears.



NOTE: If there is an installation error, you might need to install the digitally signed monitor .INF and .ICM files from <http://www.hp.com/support>.

For best results, download the auto-adjustment test pattern utility available on <http://www.hp.com/support>.

If necessary, restore the default settings and then attempt to optimize image performance again. To restore factory settings, press **Menu**. Select **Factory Reset**, and then select **Yes**.

Because the Phase settings are dependent on the main Clock setting, you must first correctly adjust the Clock setting.

To eliminate vertical bars using the Clock setting:

1. Press **Menu**. In the OSD menu, select **Image Control**, and then select **Clock and Phase**.
2. Use the up- and down-arrow function buttons on the bottom of the monitor front bezel to eliminate the vertical bars.



TIP: Slowly press the buttons to make sure that you do not miss the optimum adjustment point.

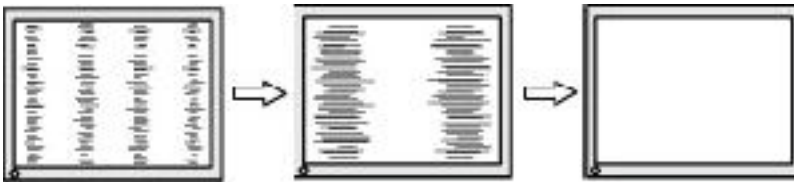

3. After adjusting the Clock setting, if blurring or flickering appears on the screen, adjust the Phase setting.

To remove blurring or flickering using the Phase setting:

1. Press **Menu**. In the OSD menu, select **Image Control**, and then select **Clock and Phase**.
2. Use the up- and down-arrow function buttons on the bottom of the monitor front bezel to eliminate the blurring or flickering.



NOTE: Depending on your computer and graphics card, it might not be possible to completely eliminate blurring or flickering.

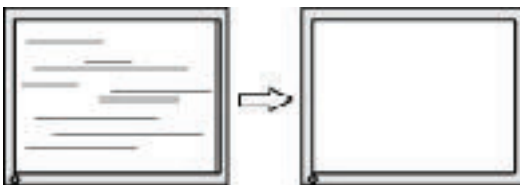

To correct the horizontal or vertical screen position:

1. Press **Menu**. In the OSD menu, select **Image Position**.

2. Use the up- and down-arrow function buttons on the bottom of the monitor front bezel to adjust the image position in the display area of the monitor. Horizontal Position shifts the image left or right; Vertical Position shifts the image up or down.

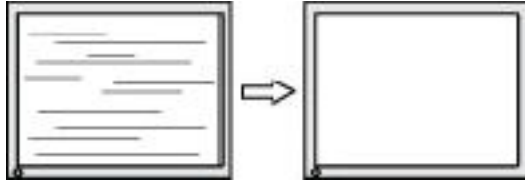

Contacting support

To resolve a hardware or software problem, go to <http://www.hp.com/support>. Use this site to get more information about your product, including links to discussion forums and instructions on troubleshooting. You can also find information on how to contact HP and open a support case.

Preparing to call technical support

If you cannot solve a problem using the troubleshooting tips in this section, you may need to call technical support. Have the following information available when you call:

- Monitor model number
- Monitor serial number
- Purchase date on invoice
- Conditions under which the problem occurred
- Error messages received
- Hardware configuration
- Name and version of the hardware and software you are using

Locating the serial number and product number

The serial number and product number are located on a label on the back of the monitor. You may need these numbers when contacting HP about the monitor.

 **NOTE:** You might need to pivot the monitor to read the label.

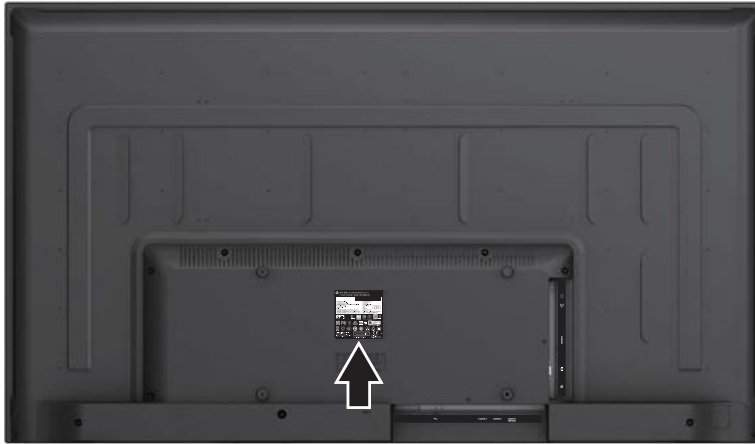

5 Maintaining the monitor

Maintenance guidelines

To enhance the performance and extend the life of the monitor:

- Do not open the monitor cabinet or attempt to service this product yourself. Adjust only those controls that are covered in the operating instructions. If the monitor is not operating properly or has been dropped or damaged, contact an authorized HP dealer, reseller, or service provider.
- Use only a power source and connection appropriate for this monitor, as indicated on the label/back plate of the monitor.
- Be sure the total ampere rating of the products connected to the outlet does not exceed the current rating of the AC outlet, and the total ampere rating of the products connected to the cord does not exceed the rating of the cord. Look on the power label to determine the ampere rating (AMPS or A) for each device.
- Install the monitor near an outlet that you can easily reach. Disconnect the monitor by grasping the plug firmly and pulling it from the outlet. Never disconnect the monitor by pulling the cord.
- Turn the monitor off when not in use. You can substantially increase the life expectancy of the monitor by using a screen saver program and turning off the monitor when not in use.



NOTE: A burned-in image on the monitor screen is not covered under the HP warranty.

- Slots and openings in the cabinet are provided for ventilation. These openings must not be blocked or covered. Never push objects of any kind into cabinet slots or other openings.
- Do not drop the monitor or place it on an unstable surface.
- Do not allow anything to rest on the power cord. Do not walk on the power cord.
- Keep the monitor in a well-ventilated area, away from excessive light, heat, or moisture.
- When removing the monitor stand, you must position the monitor facedown on a soft area to prevent it from getting scratched, defaced, or broken.

Cleaning the monitor

1. Turn off the monitor and unplug the power cord from the AC outlet.
2. Disconnect any external devices.
3. Dust the monitor by wiping the screen and the cabinet with a soft, clean antistatic cloth.
4. For more difficult cleaning situations, use a 50/50 mix of water and isopropyl alcohol.



IMPORTANT:

- Do not use cleaners that contain any petroleum-based materials such as benzene, thinner, or any volatile substance to clean the monitor screen or cabinet. These chemicals may damage the monitor.
 - Spray the cleaner onto a cloth and use the damp cloth to gently wipe the screen surface. Never spray the cleaner directly on the screen surface. It may run behind the bezel and damage the electronics.
 - The cloth should be moist, but not wet. Water dripping into the ventilation or other points of entry can cause damage to the monitor. Allow the unit to air-dry before use.
-

Shipping the monitor

Keep the original packing box in a storage area. You may need it later if you move or ship the monitor.

A Technical specifications



NOTE: All specifications represent the typical specifications; actual performance may vary either higher or lower.

The product specifications provided in the user guide might have changed between the time of manufacturing and delivery of your product.

For the latest specifications or additional specifications on this product, go to <http://www.hp.com/go/quickspecs/> and search for your monitor model to find the model-specific QuickSpecs.

Feature	Specification	
Display	139.7 cm wide screen	55-inch wide screen
Type	ADS	
Viewable image size	137.7 cm diagonal	55-inch diagonal
Maximum weight (unpacked)	14.0 kg	30.86 lb
Dimensions		
Height	72.12 cm	28.41 in
Depth	6.99 cm	2.75 in
Width	124.16 cm	48.88 in
Maximum graphic resolution	3840 × 2160	
Optimum graphic resolution	3840 × 2160	
Environmental requirements		
Operating temperature	5°C to 35°C	41°F to 95°F
Storage temperature	-34°C to 60°C	-29°F to 140°F
Relative humidity	20% to 80%	
Operating altitude	0 m to 5,000 m	0 to 16,400 ft
Storage altitude	0 m to 12,192 m	0 to 40,000 ft
Power source	100 V ac to 240 V ac 50/60 Hz	
Input terminal	One VGA port, three HDMI ports, one DisplayPort	

Audio feature	Specification	
Speaker output	RMS Audio Output	6 W + 6 W (R + L)
	Speaker impedance	8 Ω
Audio output (headphones)	3.5 mm audio-out jack	
Audio input	3.5 mm audio-in jack	

Preset display resolutions

The display resolutions listed below are the most commonly used modes and are set as factory defaults. This monitor automatically recognizes these preset modes and they will appear properly sized and centered on the screen.

Preset	Pixel format	Horz freq (kHz)	Vert freq (Hz)	Pixel Clk (MHz)
1	640 × 480	31.469	59.940	25.175
2	720 × 400	31.469	70.087	28.322
3	800 × 600	37.879	60.317	40.000
4	1024 × 768	48.363	60.004	65.000
5	1280 × 1024	63.981	60.020	108.000
6	1440 × 900	55.935	59.887	106.500
7	1600 × 900	60.000	60.000	108.000
8	1920 × 1080	67.500	60.000	148.500
9	1920 × 1200	74.556	59.885	154.000
10	2560 × 1440*	88.787	59.951	241.500
11	2560 × 1600*	98.713	59.972	268.500
12	3480 × 2160*,**	133.313	59.997	533.250



NOTE: * VGA connections do not support 2560 × 1440, 2560 × 1600, or 3480 × 2160 @ 60 Hz timing mode.
** HDMI 2 and HDMI 3 connections do not support 3480 × 2160 @ 60 Hz timing mode.

Entering user modes

The video controller signal may occasionally call for a mode that is not preset in the following conditions:

- You are not using a standard graphics adapter.
- You are not using a preset mode.

If this occurs, you may need to readjust the parameters of the monitor screen by using the OSD. Your changes can be made to any or all of these modes and saved in memory. The monitor automatically stores the new setting, and then recognizes the new mode just as it does a preset mode. In addition to the factory preset modes, there are at least 10 user modes that can be entered and stored.

Energy saver feature

The monitor supports a reduced power state. The reduced power state will be initiated if the monitor detects the absence of either the horizontal sync signal or the vertical sync signal. Upon detecting the absence of these signals, the monitor screen is blanked, the backlight is turned off, and the power light turns amber. When the monitor is in the reduced power state, the monitor will utilize 0.5 watts of power. There is a brief warm-up period before the monitor will return to its normal operating state.

Refer to the computer manual for instructions on setting the energy saver mode (sometimes called power management feature).



NOTE: The above energy saver feature works only when the monitor is connected to a computer that has energy saver features.

By selecting the settings in the monitor's Sleep Timer utility, you can also program the monitor to enter into the reduced power state at a predetermined time. When the monitor's Sleep Timer utility initiates the reduced power state, the power light blinks amber.

B Accessibility

Accessibility

HP is working to weave diversity, inclusion and work/life into the fabric of our company, so it is reflected in everything we do. Here are some examples of how we are putting differences to work to create an inclusive environment focused on connecting people to the power of technology throughout the world.

Finding the technology tools you need

Technology can unleash your human potential. Assistive technology removes barriers and helps you create independence at home, at work, and in the community. Assistive technology helps increase, maintain, and improve the functional capabilities of electronic and information technology. For more information, see [Finding the best assistive technology on page 29](#).

Our commitment

HP is committed to providing products and services that are accessible for people with disabilities. This commitment supports our company's diversity objectives and helps us ensure that the benefits of technology are available to all.

Our accessibility goal is to design, produce, and market products and services that can be effectively used by everyone, including people with disabilities, either on a stand-alone basis or with appropriate assistive devices.

To achieve our goal, this Accessibility Policy establishes seven key objectives to guide our actions as a company. All HP managers and employees are expected to support these objectives and their implementation in accordance with their roles and responsibilities:

- Raise the level of awareness of accessibility issues within our company, and provide our employees with the training they need to design, produce, market, and deliver accessible products and services.
- Develop accessibility guidelines for products and services, and hold product development groups accountable for implementing these guidelines where competitively, technically, and economically feasible.
- Involve people with disabilities in the development of accessibility guidelines, and in the design and testing of products and services.
- Document accessibility features and make information about our products and services publicly available in an accessible form.
- Establish relationships with leading assistive technology and solution providers.
- Support internal and external research and development that will improve assistive technology relevant to our products and services.
- Support and contribute to industry standards and guidelines for accessibility.

International Association of Accessibility Professionals (IAAP)

IAAP is a not-for-profit association focused on advancing the accessibility profession through networking, education, and certification. The objective is to help accessibility professionals develop and advance their careers and to better enable organizations to integrate accessibility into their products and infrastructure.

HP is a founding member, and we joined to participate with other organizations to advance the field of accessibility. This commitment supports our company's accessibility goal of designing, producing, and marketing products and services that can be effectively used by people with disabilities.

IAAP will make our profession strong by globally connecting individuals, students, and organizations to learn from one another. If you are interested in learning more, go to <http://www.accessibilityassociation.org> to join the online community, sign up for newsletters, and learn about membership options.

Finding the best assistive technology

Everyone, including people with disabilities or age-related limitations, should be able to communicate, express themselves, and connect with the world using technology. HP is committed to increasing accessibility awareness within HP and with our customers and partners. Whether it's large fonts that are easy on the eyes, voice recognition that lets you give your hands a rest, or any other assistive technology to help with your specific situation—a variety of assistive technologies make HP products easier to use. How do you choose?

Assessing your needs

Technology can unleash your potential. Assistive technology removes barriers and helps you create independence at home, at work, and in the community. Assistive technology (AT) helps increase, maintain, and improve the functional capabilities of electronic and information technology.

You may choose from many AT products. Your AT assessment should allow you to evaluate several products, answer your questions, and facilitate your selection of the best solution for your situation. You will find that professionals qualified to do AT assessments come from many fields, including those licensed or certified in physical therapy, occupational therapy, speech/language pathology, and other areas of expertise. Others, while not certified or licensed, may also provide evaluation information. You will want to ask about the individual's experience, expertise, and fees to determine if they are appropriate for your needs.

Accessibility for HP products

The following links provide information about accessibility features and assistive technology, if applicable, included in various HP products. These resources will help you select the specific assistive technology features and product(s) most appropriate for your situation.

- [HP Elite x3—Accessibility Options \(Windows 10 Mobile\)](#)
- [HP PCs—Windows 7 Accessibility Options](#)
- [HP PCs—Windows 8 Accessibility Options](#)
- [HP PC's—Windows 10 Accessibility Options](#)
- [HP Slate 7 Tablets—Enabling Accessibility Features on Your HP Tablet \(Android 4.1/Jelly Bean\)](#)
- [HP SlateBook PCs—Enabling Accessibility Features \(Android 4.3, 4.2/Jelly Bean\)](#)
- [HP Chromebook PCs—Enabling Accessibility Features on Your HP Chromebook or Chromebox \(Chrome OS\)](#)
- [HP Shopping—peripherals for HP products](#)

If you need additional support with the accessibility features on your HP product, see [Contacting support on page 34](#).

Additional links to external partners and suppliers that may provide additional assistance:

- [Microsoft Accessibility information \(Windows 7, Windows 8, Windows 10, Microsoft Office\)](#)
- [Google Products accessibility information \(Android, Chrome, Google Apps\)](#)

- [Assistive Technologies sorted by impairment type](#)
- [Assistive Technologies sorted by product type](#)
- [Assistive Technology vendors with product descriptions](#)
- [Assistive Technology Industry Association \(ATIA\)](#)

Standards and legislation

Standards

Section 508 of the Federal Acquisition Regulation (FAR) standards was created by the US Access Board to address access to information and communication technology (ICT) for people with physical, sensory, or cognitive disabilities. The standards contain technical criteria specific to various types of technologies, as well as performance-based requirements which focus on functional capabilities of covered products. Specific criteria cover software applications and operating systems, web-based information and applications, computers, telecommunications products, video and multi-media, and self-contained closed products.

Mandate 376 – EN 301 549

The EN 301 549 standard was created by the European Union within Mandate 376 as the basis for an online toolkit for public procurement of ICT products. The standard specifies the functional accessibility requirements applicable to ICT products and services, together with a description of the test procedures and evaluation methodology for each accessibility requirement.

Web Content Accessibility Guidelines (WCAG)

Web Content Accessibility Guidelines (WCAG) from the W3C's Web Accessibility Initiative (WAI) helps web designers and developers create sites that better meet the needs of people with disabilities or age-related limitations. WCAG advances accessibility across the full range of web content (text, images, audio, and video) and web applications. WCAG can be precisely tested, is easy to understand and use, and allows web developers flexibility for innovation. WCAG 2.0 has also been approved as [ISO/IEC 40500:2012](#).

WCAG specifically addresses barriers to accessing the web experienced by people with visual, auditory, physical, cognitive, and neurological disabilities, and by older web users with accessibility needs. WCAG 2.0 provides characteristics of accessible content:

- **Perceivable** (for instance, by addressing text alternatives for images, captions for audio, adaptability of presentation, and color contrast)
- **Operable** (by addressing keyboard access, color contrast, timing of input, seizure avoidance, and navigability)
- **Understandable** (by addressing readability, predictability, and input assistance)
- **Robust** (for instance, by addressing compatibility with assistive technologies)

Legislation and regulations

Accessibility of IT and information has become an area of increasing legislative importance. This section provides links to information about key legislation, regulations, and standards.

- [United States](#)
- [Canada](#)
- [Europe](#)

- [United Kingdom](#)
- [Australia](#)
- [Worldwide](#)

United States

Section 508 of the Rehabilitation Act specifies that agencies must identify which standards apply to the procurement of ICT, perform market research to determine the availability of accessible products and services, and document the results of their market research. The following resources provide assistance in meeting Section 508 requirements:

- www.section508.gov
- [Buy Accessible](#)

The U.S. Access Board is currently updating the Section 508 standards. This effort will address new technologies and other areas where the standards need to be modified. For more information, go to [Section 508 Refresh](#).

Section 255 of the Telecommunications Act requires telecommunications products and services to be accessible to people with disabilities. FCC rules cover all hardware and software telephone network equipment and telecommunications equipment used in the home or office. Such equipment includes telephones, wireless handsets, fax machines, answering machines, and pagers. FCC rules also cover basic and special telecommunications services, including regular telephone calls, call waiting, speed dialing, call forwarding, computer-provided directory assistance, call monitoring, caller identification, call tracing, and repeat dialing, as well as voice mail and interactive voice response systems that provide callers with menus of choices. For more information, go to [Federal Communication Commission Section 255 information](#).

21st Century Communications and Video Accessibility Act (CVAA)

The CVAA updates federal communications law to increase the access of persons with disabilities to modern communications, updating accessibility laws enacted in the 1980s and 1990s to include new digital, broadband, and mobile innovations. Regulations are enforced by the FCC and documented as 47 CFR Part 14 and Part 79.

- [FCC Guide on the CVAA](#)

Other U.S. legislation and initiatives

- [Americans with Disabilities Act \(ADA\), Telecommunications Act, the Rehabilitation Act and others](#)

Canada

The Accessibility for Ontarians with Disabilities Act was established to develop and implement accessibility standards to make goods, services, and facilities accessible to Ontarians with disabilities and to provide for the involvement of persons with disabilities in the development of the accessibility standards. The first standard of the AODA is the customer service standard; however, standards for transportation, employment, and information and communication are also being developed. The AODA applies to the Government of Ontario, the Legislative Assembly, every designated public sector organization, and to every other person or organization that provides goods, services, or facilities to the public or other third parties and that has at least one employee in Ontario; and accessibility measures must be implemented on or before January 1, 2025. For more information, go to [Accessibility for Ontarians with Disability Act \(AODA\)](#).

Europe

EU Mandate 376 ETSI Technical Report ETSI DTR 102 612: "Human Factors (HF); European accessibility requirements for public procurement of products and services in the ICT domain (European Commission Mandate M 376, Phase 1)" has been released.

Background: The three European Standardization Organizations have set up two parallel project teams to carry out the work specified in the European Commission "Mandate 376 to CEN, CENELEC and ETSI, in Support of Accessibility Requirements for Public Procurement of Products and Services in the ICT Domain."

ETSI TC Human Factors Specialist Task Force 333 has developed ETSI DTR 102 612. Further details about the work performed by STF333 (e.g., Terms of Reference, specification of the detailed work tasks, time plan for the work, previous drafts, listing of comments received and means to contact the task force) can be found at the [Special Task Force 333](#).

The parts relating to the assessment of suitable testing and conformity schemes were carried out by a parallel project, detailed in CEN BT/WG185/PT. For further information, go to the CEN project team website. The two projects are closely coordinated.

- [CEN project team](#)
- [European Commission mandate for e-accessibility \(PDF 46KB\)](#)

United Kingdom

The Disability Discrimination Act of 1995 (DDA) was enacted to ensure that websites are accessible to blind and disabled users in the United Kingdom.

- [W3C UK Policies](#)

Australia

The Australian government has announced their plan to implement [Web Content Accessibility Guidelines 2.0](#).

All Australian government websites will require Level A compliance by 2012, and Double A by 2015. The new standard replaces WCAG 1.0, which was introduced as a mandated requirement for agencies in 2000.

Worldwide

- [JTC1 Special Working Group on Accessibility \(SWG-A\)](#)
- [G3ict: The Global Initiative for Inclusive ICT](#)
- [Italian accessibility legislation](#)
- [W3C Web Accessibility Initiative \(WAI\)](#)

Useful accessibility resources and links

The following organizations may be good resources for information about disabilities and age-related limitations.



NOTE: This is not an exhaustive list. These organizations are provided for informational purposes only. HP assumes no responsibility for information or contacts you may encounter on the Internet. Listing on this page does not imply endorsement by HP.

Organizations

- American Association of People with Disabilities (AAPD)
- The Association of Assistive Technology Act Programs (ATAP)
- Hearing Loss Association of America (HLAA)
- Information Technology Technical Assistance and Training Center (ITTATC)
- Lighthouse International
- National Association of the Deaf
- National Federation of the Blind
- Rehabilitation Engineering & Assistive Technology Society of North America (RESNA)
- Telecommunications for the Deaf and Hard of Hearing, Inc. (TDI)
- W3C Web Accessibility Initiative (WAI)

Educational institutions

- California State University, Northridge, Center on Disabilities (CSUN)
- University of Wisconsin - Madison, Trace Center
- University of Minnesota computer accommodations program

Other disability resources

- ADA (Americans with Disabilities Act) Technical Assistance Program
- Business & Disability network
- EnableMart
- European Disability Forum
- Job Accommodation Network
- Microsoft Enable
- U.S. Department of Justice - A Guide to disability rights Laws

HP links

[Our contact webform](#)

[HP comfort and safety guide](#)

[HP public sector sales](#)

Contacting support



NOTE: Support is in English only.

- Customers who are deaf or hard of hearing that have questions about technical support or accessibility of HP products:
 - Use TRS/VRS/WebCapTel to call (877) 656-7058 Monday through Friday, 6 a.m. to 9 p.m. Mountain Time.
- Customers with other disabilities or age-related limitations who have questions about technical support or accessibility of HP products, choose one of the following options:
 - Call (888) 259-5707 Monday through Friday, 6 a.m. to 9 p.m. Mountain Time.
 - Complete the [Contact form for people with disabilities or age-related limitations](#).